

VG4000 Electric Zone Valves

VG4000 Series High-Capacity/High-Closeoff Electric Zone Valves are designed to regulate the flow of water in response to the demand of a controller in zone and Variable Air Volume (VAV) reheat coil applications. The high-capacity/high-closeoff capability of the VG4400xx-C and VG4800xx-C also makes this family of valves an ideal choice for fan coil and baseboard radiation applications. Normally Closed (N.C.) VG4000 series valve is designed for use with VA-7010 Series on/off control actuators and VA-7480 Series floating or proportional control actuators. These electric actuators can be order separately for field installation.



Figure 1: VG4000 Series High-Capacity/High-Closeoff Electric Zone Valves

Refer to the VA-7010 Series Electric On/Off Actuator Product/Technical Bulletin or the VA-7480 Electronic Valve Actuator Product/Technical Bulletin for specific information regarding either actuator series.

Features and Benefits

Forged Brass Body and Stainless Steel Stem and Spring	Ensures long life
Ideal for Zone, VAV Reheat Coil, Fan Coil, and Baseboard Radiation Applications	Offers a broad range of applications
EPT Rubber Plug for Bubble-Tight Shutoff	Maximizes energy savings
Easy, Field-Replaceable Packing	Shortens repairing time
Actuator can be Field Installed After Piping	Simplifies installation in confined locations
Built-In Return Spring for VA-7010 Series Electric Actuators	Allows the valve to return to normal position when the actuator is de-energized

Table 1: Ordering Code for VG4000 Series Zone Valve with Threaded (Internal BSP) End Connections

Valve Code Number	Size (in.)	Kv	Close-off Pressure* (PSIG)	On/Off	On/Off	On/Off	Floating	0 ~ 10VDC Proportional
				24VAC 50/60Hz	120VAC 50/60Hz	230VAC 50/60Hz	24VAC 50/60Hz	24VAC 50/60Hz
				VA-7010-8001**	VA-7010-8502-C	VA-7010-8503-C	VA-7480-0011**	VA-7482-0011**
Two-Way N.C. (Push-Down-to-Open, PDT0)								
VG4400FC-C	1/2	2.1 ~ 2.2	50 (345kPa)	Yes	Yes	Yes	Yes	Yes
VG4400GC-C	3/4	2.5 ~ 2.6	50 (345kPa)	Yes	Yes	Yes	Yes	Yes
VG4400HC-C	1	3.0 ~ 3.1	50 (345kPa)	Yes	Yes	Yes	Yes	Yes
Three-Way N.C. (Push-Down-to-Open, PDT0)								
VG4800FC-C	1/2	2.1 ~ 2.2	50 (345kPa)	Yes	Yes	Yes	Yes	Yes
VG4800GC-C	3/4	2.5 ~ 2.6	50 (345kPa)	Yes	Yes	Yes	Yes	Yes

* The close-off pressure for three-way mixing valves is 50 psig(345kPa) on the normally closed port and 25 psig(172kPa) on the normally open port.

** Imported types

Table 2: Drop (PSI) vs. Flow Rate in Gallons per Minute (GPM)

Pipe Size (Sweat or Threaded End Connections)	1/2 in.	3/4 in.	1 in.
Kv	2.1 ~ 2.2	2.5 ~ 2.6	3.0 ~ 3.1
Pressure Drop (PSI)	Flow Rate (GPM)		
1	2.6	3.0	3.6
2	3.6	4.3	5.1
3	4.5	5.3	6.3
4	5.1	6.1	7.3
5	5.8	6.8	8.1
6	6.3	7.5	8.9
7	6.8	8.0	9.6
8	7.3	8.6	10.3
9	7.7	9.1	10.9
10	8.1	9.6	11.5
11	8.5	10.1	12.0
12	8.9	10.5	12.6
13	9.3	11.0	13.1
14	9.6	11.4	13.6
15	10.0	11.8	14.0
16	10.3	12.2	14.5
17	10.6	12.5	15.0
18	10.9	12.9	15.4
19	11.2	13.3	15.8
20	11.5	13.6	16.2
21	11.8	13.9	16.6
22	12.1	14.3	17.0
23	12.3	14.6	17.4
24	12.6	14.9	17.8
25	12.9	15.2	18.1
26	13.1	15.5	18.5
27	13.4	15.8	18.8
28	13.6	16.1	19.2
29	13.9	16.4	19.5
30	14.1	16.7	19.9

Actuator Assemblies

VG4400/4800 Series High-Capacity/High-Close-off Electric Zone Valves are specifically designed for use with VA-7010 Series on/off control actuators and VA-7480 Series floating or proportional control actuators.

Note: For soldering reasons, factory-ordered assemblies featuring sweat end connections are shipped with the actuator separated from the valve body.

Operation

IMPORTANT:

It is recommended that the VG4000 Series Valve be mounted within 90 degrees of the upright position.

VA-7010 Series (On/Off Control)

When power is applied to the actuator, the motor drives the gear assembly, pushing the valve stem down against the force of the return spring. When power is removed, the actuator retracts, allowing the return spring to move the valve stem up in the direction of its normal position. Figure 2 illustrates the effect that valve stem movement has on flow.

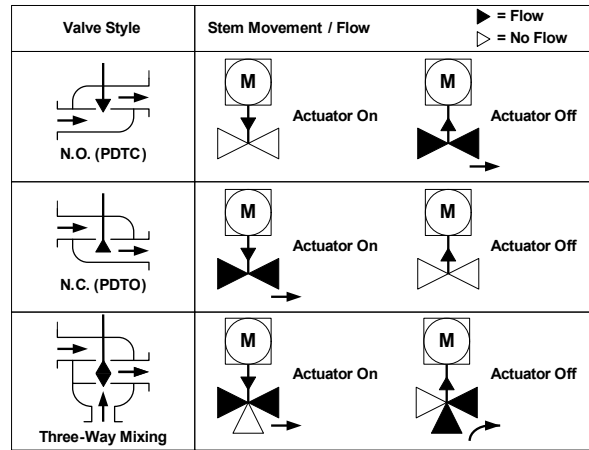

Figure 2: Effect of Valve Stem Movement on Flow

VA-7480-0011 (Floating Control)

When power is applied to the Common (black) and Down (red) wires, the motor drives the gear assembly, pushing the valve stem down against the force of the return spring. When power is applied to the Common (black) and Up (orange) wires, the actuator retracts, allowing the return spring to move the valve stem up to its normal position. When power is removed, the actuator will hold its position.

If power remains applied to either the red or orange wire, the actuator will time out and shut the motor off after approximately 90 seconds, holding its current position. Figure 2 illustrates the effect that valve stem movement has on flow.

VA-7482-0011 (Proportional Control)

When the control signal increases, the actuator motor drives the gear assembly, pushing the valve stem down against the force of the return spring.

When the control signal decreases, the actuator retracts, allowing the return spring to move the valve stem up in the direction of its normal position.

Upon loss of power, the actuator will hold its position. Figure 2 illustrates the effect that valve stem movement has on flow.

Dimensions

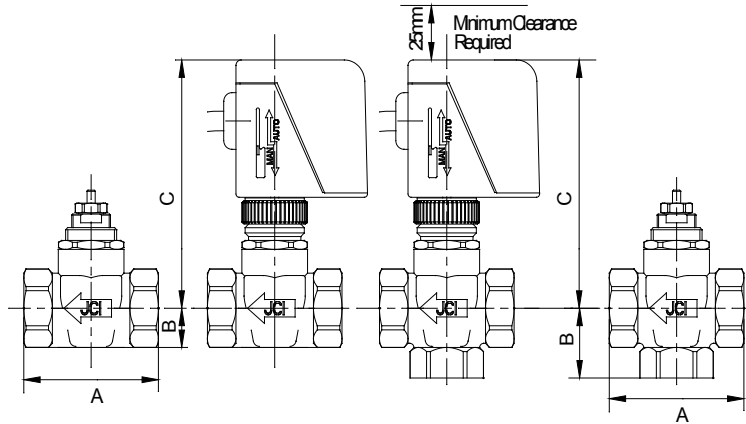

Figure 3: VA-7010 Actuated VG4000 Series Valve Dimensions, in. (mm) (Refer to Table 3)

Table 3: Dimensions for VA-7010 Actuated VG4400/4800 Series Assemblies with Threaded (Internal BSP) End Connections, mm

Dimension*	Two or Three-Way Valve Assemblies				
	Two-way 1/2 in. (DN15)	Two-way 3/4 in. (DN20)	Two-way 1 in. (DN25)	Three-way 1/2 in. (DN15)	Three-way 3/4 in. (DN20)
A	66	66	90	66	66
B	18	18	24	32	32
C	109	109	109	109	109

*For actuator-only dimensions, refer to the VA-7010 Series Electric On/Off Actuator Product/Technical Bulletin

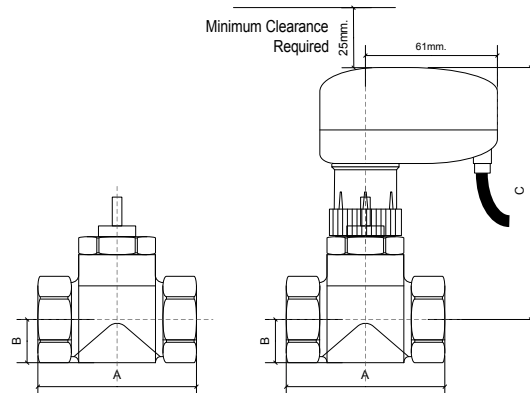

Figure 4: VA-7480 Actuated VG4000 Series Valve Dimensions, in. (mm) (Refer to Table 4)

Table 4: Dimensions for VA-7480 Actuated VG4000 Series Assemblies with Threaded (Internal BSP) End Connections, mm

Dimension*	Two or Three-Way Valve Assemblies				
	Two-way 1/2 in. (DN15)	Two-way 3/4 in. (DN20)	Two-way 1 in. (DN25)	Three-way 1/2 in. (DN15)	Three-way 3/4 in. (DN20)
A	66	66	90	66	66
B	18	18	24	32	32
C	115	115	115	115	115

* For actuator-only dimensions, refer to the VA-7480 Electronic Valve Actuator Product/Technical Bulletin

Technical Data

Product	VG4000 Series High-Capacity/High-Closeoff Electric Zone Valves				
Models	VG4400FC-C	VG4400GC-C	VG4400HC-C	VG4800FC-C	VG4800GC-C
Body Rating	PN20				
Service*	Hot and Cold Water for HVAC Systems				
Valve Sizes	1/2 in. (DN15)	3/4 in. (DN20)	1 in. (DN25)	1/2 in. (DN15)	3/4 in. (DN20)
Maximum Close-off Pressure	50 PSIG				
Leakage	0.01% of Maximum Flow; 100% Protection Tested				
End Connections	Threaded (Internal BSP)				
Stroke	3mm				
Body Type	Two-Way PDO(NC)	Two-Way PDO(NC)	Two-Way PDO(NC)	Three-Way Mixing	Three-Way Mixing
Material					
Valve Body	Forged Brass				
Packing Nut and Cage	Brass				
Stem	ANSI 300 Stainless Steel				
Spring	Stainless Steel				
Plug	EPT Rubber				
Packing	Two EPT Rubber O-Rings				
Fluid Temperature Limits	2 ~ 95°C (35 ~ 203 °F)				
Ambient Temperature Limits	2 ~ 50°C (35 ~ 122 °F)				
Flow Characteristics	On/Off with VA-7010 Series Actuator; Two-Way Valves with VA-7480 Series Actuator Approximately Equal Percentage; Three-Way Valves with VA-7480 Series Actuator Approximately Linear for Service Port				
Valve Body Shipping Weight, lb (kg):	1/2 in. (DN15 Two-Way) 1.03 (0.47)	3/4 in. (DN20 Two-Way) 0.86 (0.39)	1 in. (DN25 Two-Way) 1.52 (0.69)	1/2 in. (DN15 Three-Way) 1.14 (0.52)	3/4 in. (DN20 Three-Way) 0.95 (0.43)
Actuator Shipping Weight, lb (kg)	VA-7010 Series: 1.10 (0.50) VA-7480 Series: 0.44(0.2)				

* Proper water treatment is recommended; refer to VDI 2035 Standard.